

POLYTECHNIC UNIVERSITY

Autonomous Ground Vehicle

ME5643: Mechatronics

Joseph Ferrari

Vito Guardi

Vlad Kopman

5/19/2008

Contents

1	Abstract.....	3
2	Introduction	3
2.1	Problem Statement.....	3
2.2	Milestones.....	4
2.3	Background	5
2.3.1	GPS Technology.....	5
2.3.2	Distance and Bearing Formulas	7
3	Concept Development	9
3.1	Overall System	9
3.2	Autonomous Ground Vehicle.....	9
3.3	Wireless Communications system	12
3.4	Microcontroller – Computer Interface	13
3.5	Base Station	15
3.6	Power Distribution System	15
4	System Construction	15
4.1	Autonomous Ground Vehicle.....	15
4.2	Base Station	16
4.3	Program Overview Flow Diagrams.....	18
4.4	Safety Systems	19
5	System Testing and Results.....	20
6	Conclusions	20
7	Future Work.....	21
8	References	21
9	Appendix	21
9.1	Source code.....	21

1 Abstract

A plan to build an Autonomous Ground Vehicle (AGV) has been proposed. The targeted applications of the AGV include automated protection of an area of interest including temporary military bases and sensitive payload drop-off points. The complete system is comprised of two components; the AGV and the base munitions platform. Both are to work in bi-directional coordination allowing for the successful acquisition of enemy target position and the immediate elimination of the threat without damaging the AGV.

The AGV is required to autonomously travel from the base to a search location and perform search patterns in order to locate enemies. Once a target is located a stationary munitions station at a fixed location aims at the target and fires upon it.

Various sensors are implemented on the drone in order to gather helpful information. The drone uses GPS technology to track its own position and to mark target positions for removal. Targets are recognized via infrared sensors as the target is assumed to be tagged with an infrared beacon. Distance to the target is calculated using ultrasonic range finders. The transfer of sensor and systems status data is possible through transceiver technology. Such sensors and other components are readily available for purchase therefore making the project easily replicable and mass production realizable. A prototype of the drone and base have been constructed and successfully tested.

2 Introduction

2.1 Problem Statement

The AGV is designed to be fully autonomous; it is expected to drive around an area in a search pattern while continuously looking for targets. The AGV is meant for defensive applications of areas of

interest. Consider a situation where a battalion of troops is mobilized and in route to a certain location. It is imminent for the soldiers to rest and therefore temporary camping bases are established. An efficient way to protect the soldiers is the deployment of the proposed AGV system. A trained military officer would strategically position a base station (consisting of an automated gun platform and onboard computer systems) at the border of the base and would allow the robot to autonomously travel away from the base in a preprogrammed direction and perform search maneuvers. Once a target is located via ultrasonic detection, the AGV would mark the GPS coordinates and bearing of the target relative to the base and relay the information back to the base. The base will then aim a turret in the direction of the target.

2.2 Milestones

Due to the high complexity and grand scope of this project, it was split into many tasks.

1. Create an autonomous robot capable of sustaining a constant speed without turning.
2. Interface the autonomous robot with an ultrasonic sensor such that the robot will stop moving if a target is detected
3. Create a base station that will accept a direction (bearing) as input (expressed in degrees east of north) and point in said direction.
4. Establish wireless communications between the autonomous robot and the base station.
5. Establish communications between the base station and a computer running simulink performing complex calculations to find distance a bearing from base to target. The computer will take in GPS data and output the direction the base needs to point in.
6. Create a search algorithm that the robot will follow in order to find the target in a set area. The robot will stop moving once the target is found via use of the ultrasonic sensor.

7. Interface the GPS receiver such that the robot will send its location to the base station once a target is found.
8. Create search patterns via GPS coordinates centered on the assumed location of the target. The computer will generate these search patterns and relay the distance and bearing to the next waypoint as the robot reports its GPS location to the computer.
9. Interface a digital compass with the robot so that it can follow the search pattern described in item 8.
10. Create a more sophisticated searching algorithm that will allow the robot to report a more accurate GPS target location.
11. Incorporate a digital compass into the base station to allow greater accuracy and removing the need for calibration and proper orientation.

2.3 Background

2.3.1 GPS Technology

GPS (global positioning system) is a network of satellites (Figure 1) created by the US government to be used to establish a position anywhere on the earth. At least 24 satellites are in orbit at any given time, orbiting in groups of four in six different orbits. Nominally at most 12 satellites may be seen at a point on the earth, though as few as three may be used to obtain an accurate position measurement (in special cases).

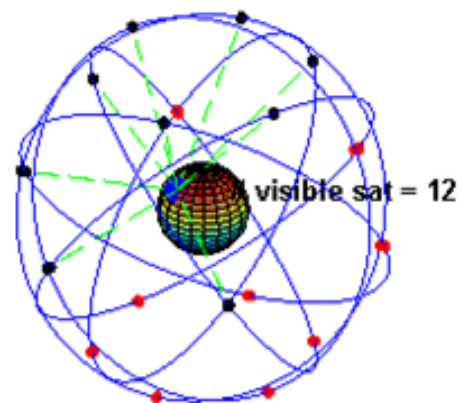

Figure 1. GPS satellite network.

This technology utilizes a precise time measurement in order to calculate the distance from a satellite to a unknown point. Once this distance is established, the point is known to be located on a

spherical surface with the center being the location of the satellite and the radius being the distance. A second satellite then finds the distance to the unknown point; therefore the point is known to reside on the surface of a second spherical surface. Since the point must satisfy these two previous conditions, the point is known to be located on a circle (the result of two intersecting spheres). Now a third sphere is created (which the point must lie on) by the distance from the unknown point to a third satellite. With these three conditions satisfied, the point is known to be in one of two positions (the result of three intersecting spheres). A fourth satellite is needed to calculate altitude, but isn't necessary in the special case when altitude is known. An example of this special case is a ship travelling constantly at sea level.

To be more precise about the functionality of GPS, simultaneous equations are solved for unknown parameters (location on x, y, z axes, altitude, time, etc.). The number of unknowns being solved for dictates the number of visible satellites necessary for a position to be calculated. The parameters calculated can then be converted to the more familiar latitude-longitude system of describing position on the earth. The latitude-longitude system may be expressed in decimal degrees (DD.DDDD°, used for calculating distance and bearing), degrees, minutes, and fractional minutes (DD°MM.MMMM', the output of some GPS modules), or degrees, minutes, and seconds (DD°MM'SS.SSSS", a common display on GPS devices).

Although the GPS is very robust, there are still errors and uncertainty. Errors arise from such factors as the non-spherical earth. The latitude-longitude system and all calculations incorporating said points (such as distance and bearing, described in the next section) are based off spherical geometry despite the fact that the Earth is not a sphere. There are corrections that may be made to account for the actual shape of the earth. Other errors stem from atmospheric effects; typically the GPS signals will not be readily available on a cloudy day. Multipath effects can cause GPS signals to be delayed,

therefore impeding accuracy. Satellite clock and ephemeris errors can cause improper data to be sent. Although it is currently disabled, the selective availability feature in the GPS used to introduce intentional errors in data. Other errors may result from relativistic effects (the frequency of the atomic clock onboard each GPS satellite is set slightly slower (10.22999999543 MHz vs 10.23 MHz [1]) than the desired frequency on the surface of the earth) and the Sagnac effect (a Lorentz transformation is applied to the measurements gathered by the satellites since said measurements are taken with respect to an inertial reference frame when they are needed in an Earth-centered, Earth-fixed system).

2.3.2 Distance and Bearing Formulas

The distance between two points on the earth may be estimated by approximating the Earth as a homogeneous sphere (as discussed in the previous section). The shortest distance on the surface of a sphere is the great-circle distance (a great circle is a circle on the surface of a sphere whose center coincides with that of the sphere). The formula for great-circle distance [2] is derived from the spherical law of cosines and is as follows.

$$d = 2R_e \sin^{-1} \left(\sqrt{\sin^2 \left(\frac{\phi_2 - \phi_1}{2} \right) + \cos \phi_1 \cos \phi_2 \sin^2 \left(\frac{\lambda_2 - \lambda_1}{2} \right)} \right) \quad (##)$$

Where (ϕ_1, λ_1) and (ϕ_2, λ_2) are the starting and ending points (latitude and longitude expressed in radians), respectively, and R_e is the radius of the earth expressed in the units of length in which distance is desired ($R_e = 20925524.9 \text{ ft}$).

Bearing (or heading), like distance, is found by approximating the earth as a homogeneous sphere and is derived from the spherical law of cosines. The formula for bearing also incorporates the function ATAN2 (found in most computer programming languages), which accepts two arguments (y and x) and finds the inverse tangent of y/x. What differentiates ATAN2 from ATAN is that while it is possible

to calculate the inverse tangent of y/x using ATAN, if it is desired to take the sign of both y and x into account decision statements are necessary. ATAN2 accepts y and x as parameters and establishes a sign convention automatically. ATAN2 will return the angle between the horizontal and a line formed by the origin and the point (x, y) . In order to use this as heading the modulus operator is used to get heading in radians east of north. This result is then converted to degrees. To summarize, the formula for bearing reads as

$$\theta = \frac{180}{\pi} \{ \text{ATAN2}[\sin(\lambda_2 - \lambda_1) \cos \lambda_2, \cos \phi_1 \sin \phi_2 - \sin \phi_1 \cos \phi_2 \cos(\lambda_2 - \lambda_1)] \% 2\pi \} \quad (\#\#)$$

Where θ is the bearing expressed in degrees east of north, and (ϕ_1, λ_1) and (ϕ_2, λ_2) are as described when calculating distance. It should be noted that the result of this bearing formula is map bearing. In order to find magnetic bearing (the bearing that would be viewed on a compass), the angle of declination (shown for the United States in Figure 2) specific to the area of operation must be added to the map bearing.

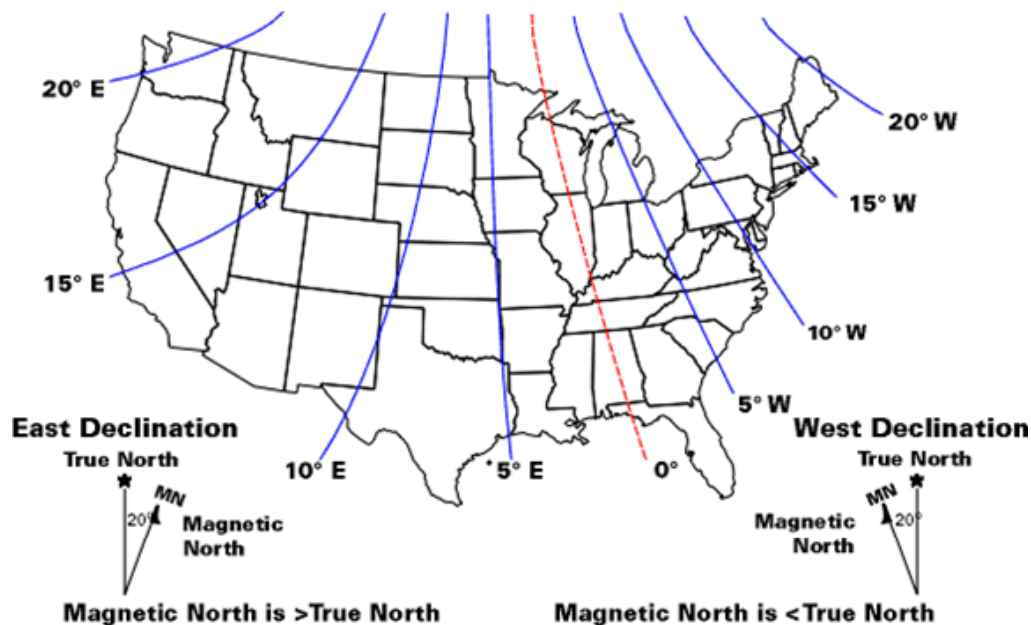

Figure 2. Angle of Declination in the United States.

3 Concept Development

3.1 Overall System

The complete system is comprised of three subsystems. The first is the autonomous ground vehicle (AGV) that will search a given area for a target. It uses an ultrasonic sensor scanning the area directly to its front and sides. The AGV will follow an algorithm that will cause it to randomly cover a specified area. The system is designed such that the general area of a target is known (within 50ft diameter) and the exact location is desired. The AGV will find this exact location and relay it to a base station. The base station will give the information received to a computer running simulink which performs calculations too complex for the microcontroller. The computer will then send the results of the calculations back to the base station and the attached turret will point in the direction of the target.

3.2 Autonomous Ground Vehicle

The AGV is designed to be robust; it will be able to adapt to less than ideal terrain. This is beneficial to the overall objective of the project. If a battalion chooses to set up camp in the middle of a jungle, this system will still be applicable due to the design of the AGV. The AGV will be able to traverse this varying terrain.

Although the AGV platform that we were provided with, the Tamiya TXT-1 was an overall great platform, it was not without its flaws. One such flaw was its outdated mechanical speed controller which provided crude speed control and lacked precision. It quickly became apparent during initial testing that the mechanical speed controllers would have to be replaced. We decided to replace it with two Viper Marine 15 Electronic Speed Controllers (one for each motor) that would allow for precision control of the AGV's speed



Figure 3 New Viper Marine 15 ESC's

Another disadvantage of the chosen platform was its poor turning radius. The solution to this problem was to add a second high torque servo to the AGV and to modify the rear suspension so that it could support four wheel steering. With this modification we can independently control both the front and rear wheel steering. After this modification the turning radius has decreased to approximately 2.5 feet.

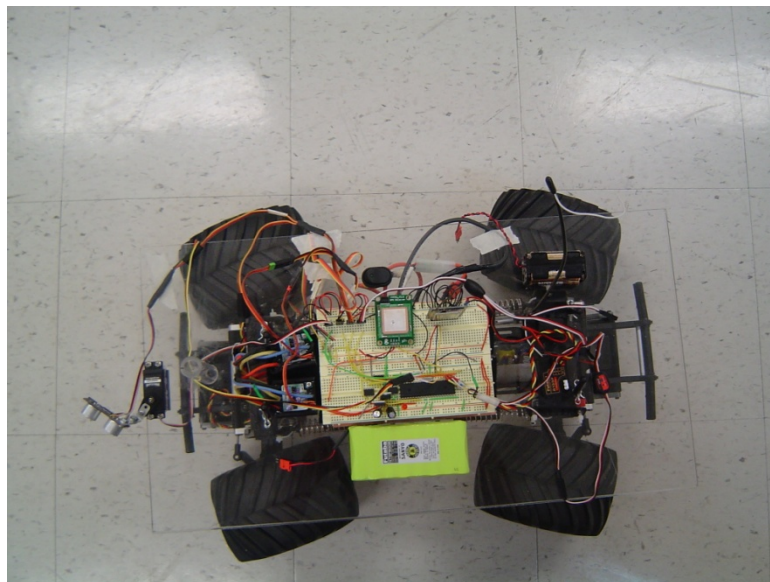

Figure 4 Example of four wheel steering on the AGV

The AGV is equipped with an opto-reflective switch mounted on one of its tires. This switch in combination with an analog-to-digital converter acts as an optical encoder and is used to measure the number of rotations of a wheel. This measurement is used to calculate the speed the AGV is travelling and the distance that the AGV has covered. The AGV is designed to travel at a constant desired speed so the optical encoder provides feedback to the system. If the measured speed is well below the desired speed, it is increased. Likewise if it is well above, it is decreased. However, if the measured speed is within a range of the desired speed, it remains unchanged. This incorporates hysteresis into the system such that chatter is eliminated and the AGV is able to maintain a constant speed.



Figure 5 Image of Opto-Reflective Switch mounted inside wheel hub

An ultrasonic sensor (Figure 6) is mounted on the front of the AGV. This sensor allows the AGV to locate targets and obstacles and take action. The sensor is attached to a 180° servo motor that is mounted to the front of the robot. The servo will continuously turn the sensor from facing the left to facing the right such that it scans an area 0.5ft-4ft in front of where it looks. The speed at which the servo rotates must be correlated with the speed at which the AGV travels such that it doesn't miss a target or obstacle on the right hand side while the sensor is facing the left hand side or visa-versa.



Figure 6. Ultrasonic sensor.

A GPS receiver mounted to the AGV will read a satellite signal and output the location in degrees, minutes, and fractional minutes for latitude and longitude, as well as direction (north or south for latitude; east or west for longitude). This data is obtained by using the smart mode on the GPS receiver as opposed to the raw mode; if the latter were to be used the output would be a string of data directly from the satellite.

3.3 Wireless Communications system

In order to transmit data from the AGV to the base station the data must be sent via a wireless RF modem. In this case we have decided to use the Parallax 912Mhz wireless transceivers because of their long range, up to 800ft and because of their simple integration with the propeller microcontroller. There is only one problem with this choice, as is the case with most low cost RF modems it is only capable of sending 8 bits at a time. This presents a problem when we are trying to send 32 bits of information for the AGV to the base station. The solution is to break up the data into 4 segments each 8 bits of data. Unfortunately this creates another problem; it greatly increases the chances of receiving bad data. Suppose we receive bytes 1, 2, and 3 but we miss byte 4, in a normal program we will just catch byte 4 on the next transmission and move on, but in this case since we need to assemble the full 32 bits of data to get what we are trying to receive we cannot just take the 4th byte sent from the second transmission and use it with bytes 1, 2, and 3 received from the first transmission. We must make sure

that all of the bytes come from the same transmission, and if there is an error and a byte is not received we must throw away all the previous data and start again with the next transmission. This is accomplished by using a few if statements and sending an identification character before each byte is transmitted.



Figure 7 Parallax 912 MHz RF Transceiver

3.4 Microcontroller – Computer Interface

In order to have the computer and microcontroller communicate, a serial object must be created and the COM port must be opened. This is done by using the `serial()` function and the `fopen()` functions in MATLAB, respectively. After the serial object is done communicating with the microcontroller, the function `fclose()` is used to close the COM port. An interface is created in order to provide a user monitoring the system with feedback. The user is provided with the GPS location of the base and robot, the number of satellites in view, whether or not a GPS signal is obtained, the distance from the base to the target, as well both the map bearing and magnetic bearing. This interface can be seen in Figure 8.

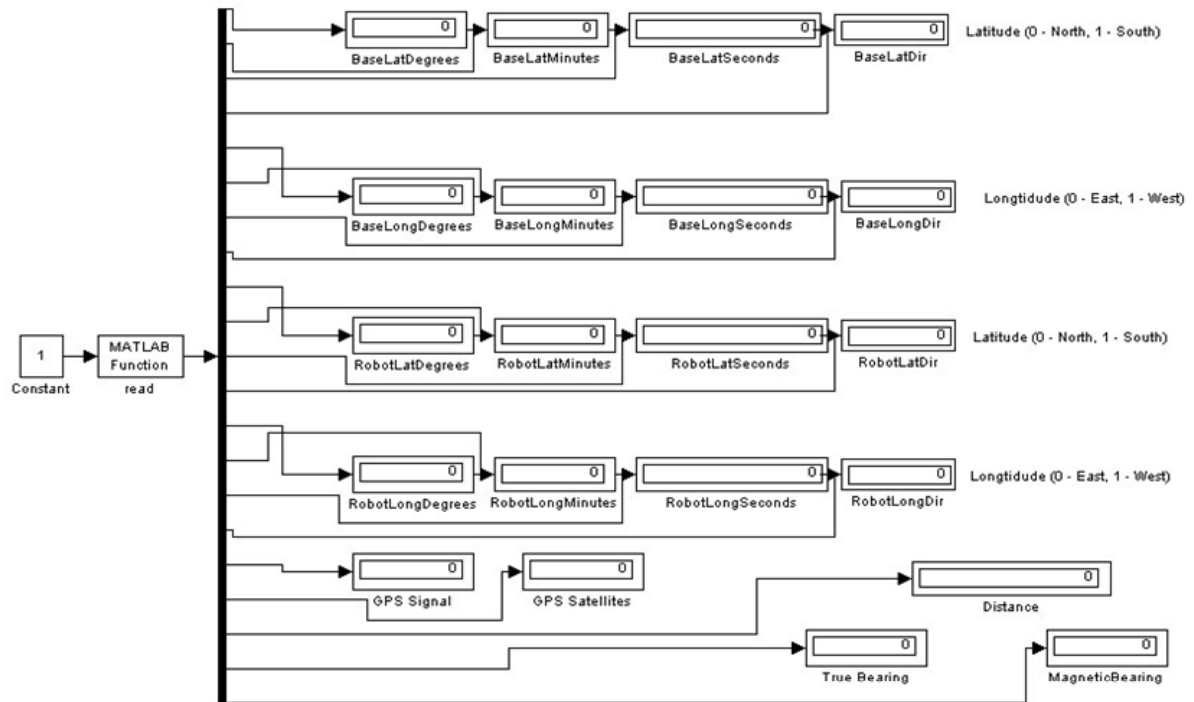

Figure 8. Simulink user interface.

The first block on the left hand side begins the simulink interface by introducing a constant. The next block calls a MATLAB function to create the serial object and open the COM port. It also calls the MATLAB function that uses the serial object in the fread() to receive data from the microcontroller. The function will then perform calculations with the received data and display results to the simulink interface. The second block outputs 21 values into a duplex with a matching dimension of 21. The display boxes are arranged aesthetically for ease of use for the user. The function will also send the results of the calculations back to the propeller microcontroller (using the fwrite() function) in order for the base station to actuate according to the input received from the AGV. It is important to keep simulink and the propeller microcontroller synced at all times or else erroneous data may be sent or received by either party. This is accomplished by sending a piece of test data and having the receiving party acknowledge this test data. Once this occurs it is safe to send the actual data.

3.5 Base Station

It is necessary for the base station to rotate in order for it to be able to point at a target specified by the AGV; therefore an actuator must be incorporated into the design. The base station will also need to stop rotating once it is pointing at the target; therefore a sensory feedback control system must be implemented. With both the sensor and actuator working together, the base station turret will point in the direction of the target.

3.6 Power Distribution System

All of the components on board the AGV required electricity to run, and most of the components run on different Voltages. The main motor on the AVG require 7.2Volt batteries and are capable of drawing a lot of current (over 4Amps). Since this is the case a separate system isolated form the rest of the circuitry was constructed to supply the motors. All wires that were required to pass current to the motor are 12gauge high quality wire, capable of handling the large amount current flowing through them. Also a similar system was constructed to power the servos used on the AGV but the wire used is a lot thinner since the current draw is significantly less than that of the main motors. Overall the goal of the power system it to supply the motors with the power they require to function properly while staying isolated from the sensitive power supply for the main circuitry.

4 System Construction

4.1 Autonomous Ground Vehicle

The circuitry needed to complete our objectives was designed and then constructed on two breadboards that can be seen below. The hardware includes a propeller microcontroller, a GPS Receiver, a wireless transmitter, a PING Ultrasonic sensor, and an ADC. Also a wiring schematic was made and can be seen below.

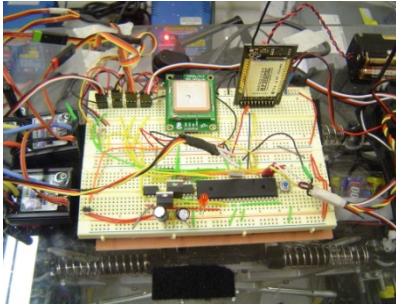

Figure 9 Circuit constructed on two breadboards

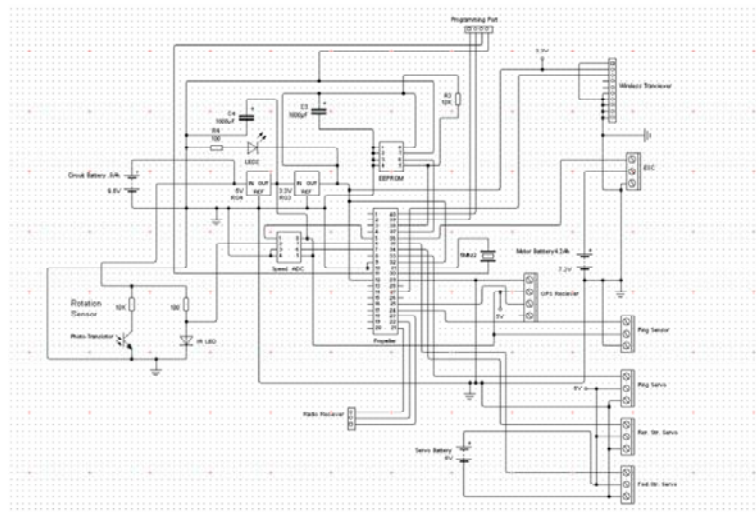

Figure 10 Wiring diagram of AGV circuit

4.2 Base Station

Considering the required performance of the structure it was well known that a part of the BASE needed to be fixed and another part—one housing the gun turret—was to rotate via some form of an actuator. The entire structure was to be built out of a sturdy yet aesthetically appealing material; Plexiglas and acrylic were the materials of choice. The



Figure 2. Lazy Susan.

rotational part of the structure required a strong base and therefore a 'Lazy Susan' (Figure 11) was used.

The actuator used to rotate the turret is a Tamiya gearbox-motor (Figure 12).

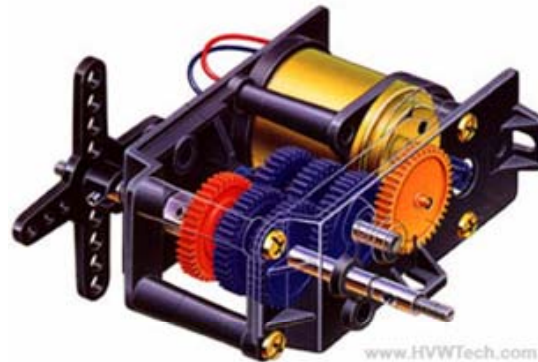

Figure 12. Tamiya 6-Speed Gearset.

The actuator was powered by 5V at a maximum of 1A. A relay H-Bridge was used to alter the direction of rotation. The only available relay H-bridge was an automotive relay and required 12V to throw. For this reason, two small reed-relays were used to throw the H-Bridge terminals with a 3.3V HIGH from the microcontroller.

Position control of the gearbox was done by attaching a multi-turn potentiometer to the rotational shaft of the gearbox. The resistance of the potentiometer varied with angular displacement therefore changing the voltage output of a voltage divider which was read by an Analog-to-Digital converter.

A transceiver module (Figure 13) was interfaced with the onboard microcontroller in order to communicate with the AGV.



Figure 13. Parallax 912 MHz RF Transceiver.

Data sent from the AGV to the base station is used in the computer to calculate bearing which causes the base to turn in the direction of the target.

4.3 Program Overview Flow Diagrams

The following flow diagram gives a general perspective of what is going on inside the microcontroller and the logic of the AGV. They also what process are going on in each cog of the propeller microcontroller.

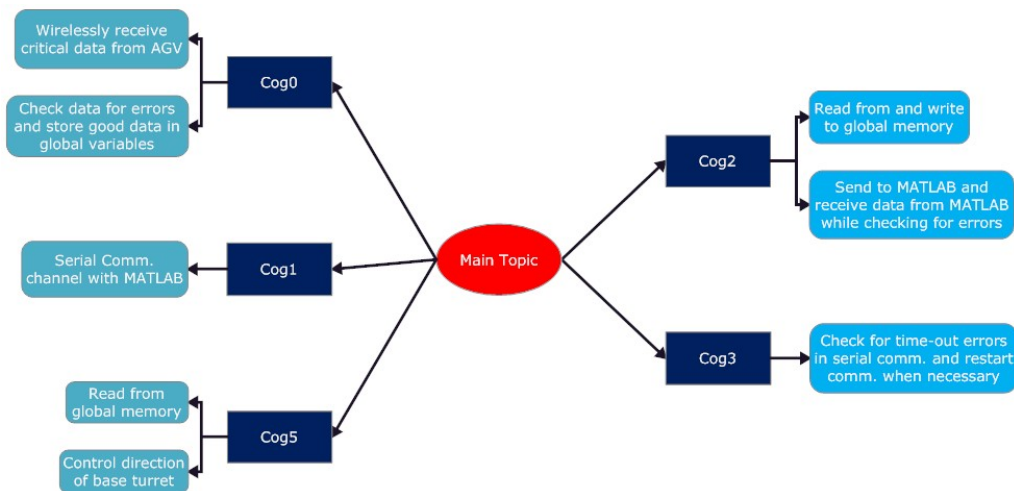

Figure 14 Flow diagram of the base propeller microcontroller

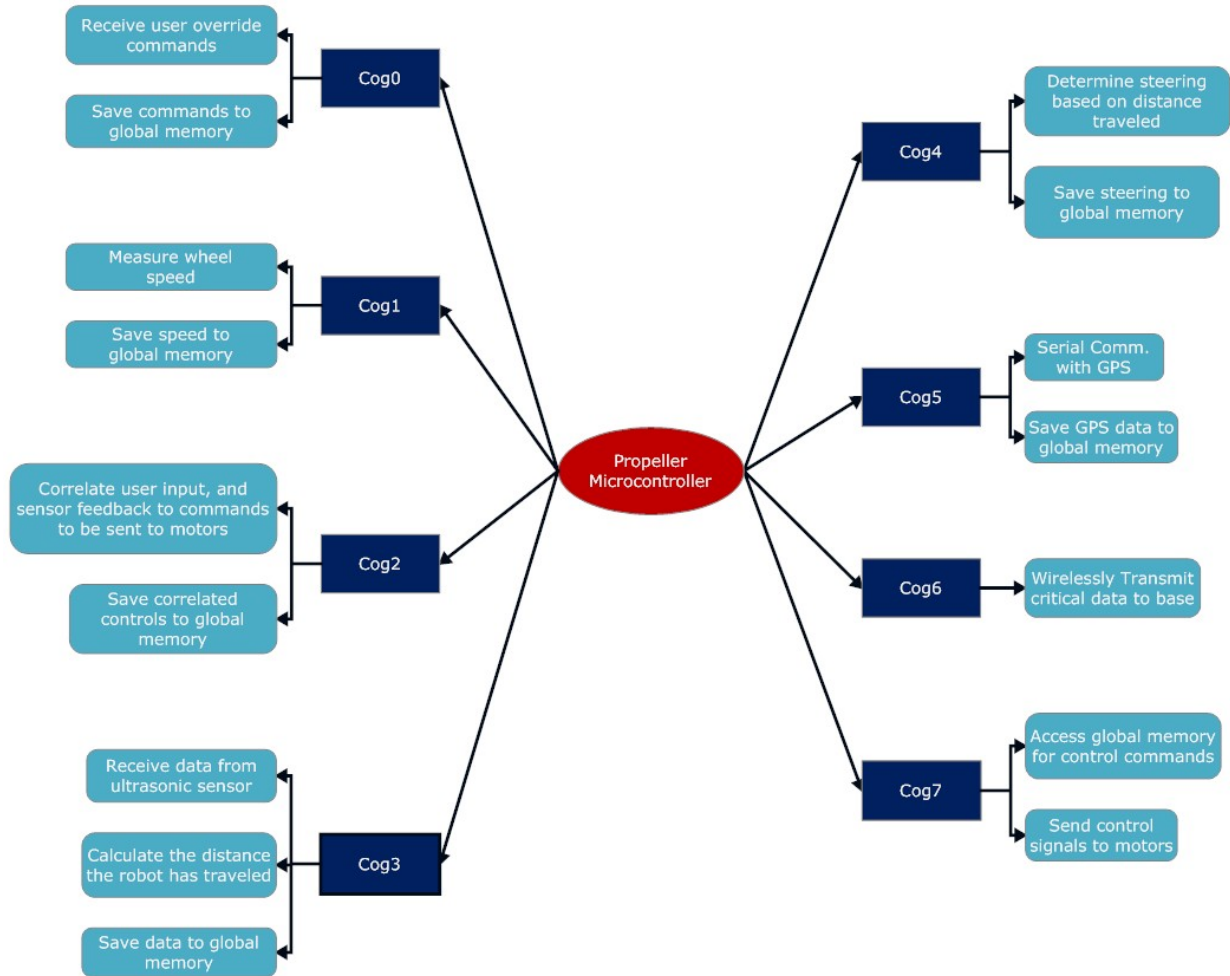

Figure 15 Flow diagram of the AGV Propeller microcontroller

4.4 Safety Systems

There are several safety systems incorporated into the AGV to help prevent the loss of control of the AGV, and minimize any damage to the AGV or its surroundings. One such safety system is the manual override option. The operator is capable of taking over control of the robots main functions by flipping a switch on the manual override transmitter. There is also a failsafe that activates, and cuts the throttle if the AGV is taken out of range of the manual override transmitter. Finally there is another fail safe built into the ESC's that cuts the throttle if the microcontroller was to dye and stop sending control commands to the ESC's.

5 System Testing and Results

When in autonomous mode, the AGV will automatically travel in an outward spiral pattern, constantly searching for a target with its ultrasonic sensor as well as sending its GPS position to the base station via RF transceiver. The AGV starts its search at a radius of 2.5ft and slowly increases this search radius up to 25ft. Once the AGV finds a target it will stop moving. This can be observed on the simulink interface by the GPS position of the AGV remaining constant. The computer connected to the base station will take the GPS location of the target relative to the base and calculate the distance and bearing to the target. The base station then points in the direction of the target. As of 5/19/2008 the weather was rainy therefore impeding the GPS signal. However, as of 5/18/2008 there were no clouds in the sky and a GPS signal was successfully obtained and sent to the base station via RF transceiver. The base station is capable of communicating with the computer via simulink and the computer is able to dictate the action of the turret. On a clear day the entire system is operational. The limitations of the system are the obvious atmospheric factors influencing the GPS signal.

6 Conclusions

An autonomous ground vehicle can serve the purpose of patrolling a specified area. If a battalion were to set up a temporary base camp, an AGV working with an artillery base station can provide a source of protection for the camp. A prototype of a system consisting of an AGV patrolling an area searching for a target and a base station capable of pointing at the target has been designed and constructed; specifically, referring to section 2.2, items one through eight have been completed. An AGV searches an area according to a search algorithm. If the AGV finds a target via an ultrasonic sensor, it relays the GPS position to the base station communicating with a simulink-enabled computer. The base station then points in the direction of the target. Portability of this project is easily realizable as well as mass production. Future work to accompany this project can be found in section 8.

7 Future Work

Items one through eight listed in section 2.2 have been completed. As future work the remaining items should be completed. Furthermore, a more robust method for finding targets would be necessary. Using a form of thermal detection for target recognition may prove useful. Friendly targets would also be detected but they would be tagged with infrared beacons to differentiate them from the enemy.

The scope of this system may be increased as to include multiple AGVs or multiple turrets. A single AGV or turret may not be enough to cover a larger area or an area of complex geometry. Multiple turrets can also be placed to concentrate firepower on a single location. Three or more AGVs may be used to increase the accuracy of the location of the target by using triangulation. All of these measures can be taken to increase the scope and magnitude of this project.

8 References

1. Anonymous author. "Global Positioning System." Wikipedia. Modified on 16 May 2008. Visited on 16 May 2008 <<http://en.wikipedia.org/wiki/GPS>>
2. Anonymous author. "Great-circle distance." Wikipedia. Modified on 5 May 2008. Visited on 16 May 2008 http://en.wikipedia.org/wiki/Great_circle_distance
3. Parallax Propeller Object Exchange <http://obex.parallax.com/Parallax>
4. Propeller Web Forum <http://forums.parallax.com/forums/default.aspx?f=25>
5. Martin, Jeff, and Lindsay, Stephanie. Propeller Manual v1.0. Parallax Inc., 2006.

9 Appendix

9.1 Source code

Due to the number of files and length of each file, the source code is not presented here. The source is available in digital form and is available upon request.